

THIS DRAWING AND DESIGN IS A PROPERTY OF 'FIRETECH' AND MUST NOT BE COPIED OR LEND WITHOUT THEIR PERMISSION IN WRITING.

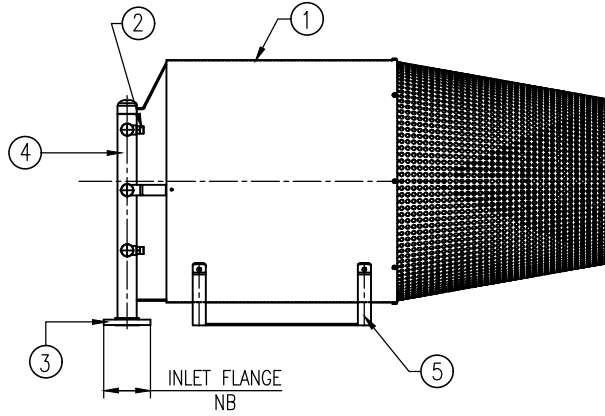

**MATERIAL OF CONSTRUCTION**

S.NO.	DESCRIPTION	MATERIAL
1	BODY	STAINLESS STEEL(SS:316)
2	NOZZLES	STAINLESS STEEL(SS:316)
3	INLET FLANGE	STAINLESS STEEL(SS:316)
4	PIPE	STAINLESS STEEL(SS:316)
5	MOUNTING FRAME	CARBON STEEL
6	FINISH	BODY-PAINTED YELLOW TO SHADE NO:356 OF IS:5
		PIPE-PAINTED FIRE-RED TO SHADE NO:536 OF IS:5

**FLOW V/S PRESSURE GRAPH**

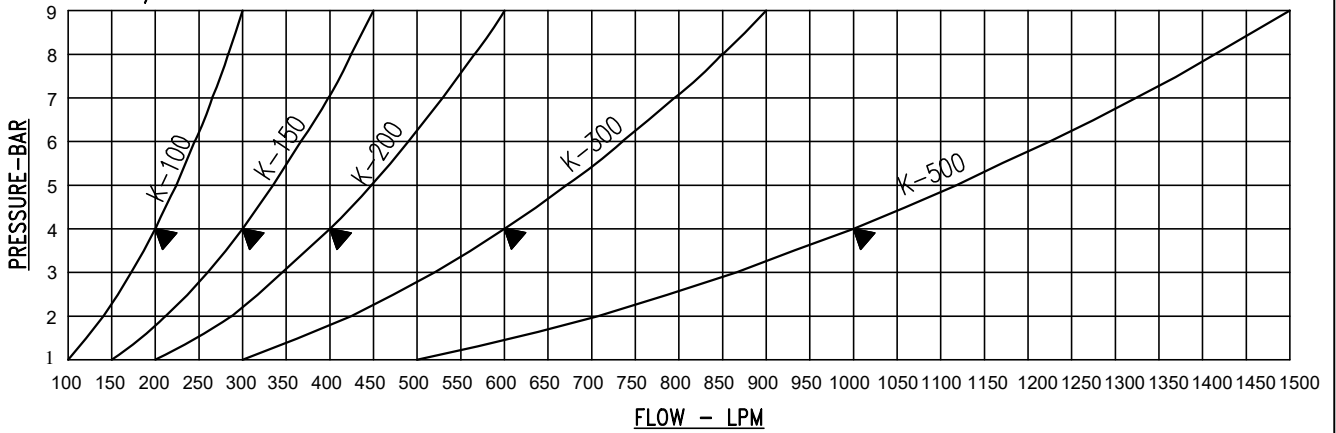

**PERFORMANCE DETAILS**

ITEM CODE	FLOW RATE IN LPM @4BAR	INLET FLANGE NB	FOAM EXPANSION	K-FACTOR	FOAM OUTPUT IN CMM
HXG-200	200 LPM	50	500	100	100
HXG-300	300 LPM	50	500	150	150
HXG-400	400 LPM	65	500	200	200
HXG-600	600 LPM	65	500	300	300
HXG-1000	1000 LPM	65	500	500	500

- NOTES: 1) ALL DIMENSION ARE IN mm, UNLESS OTHERWISE SPECIFIED.  
 2) FOAM OUTPUT MENTIONED IN CMM = CUBIC METER PER MINUTE.



HIGH EXPANSION FOAM GENERATOR  
 STAINLESS STEEL(SS-316)

DRG.NO.  
 628-MKT-A2-S6

R  
 1